

# MODEL 250TB TROUGH BED BELT CONVEYOR

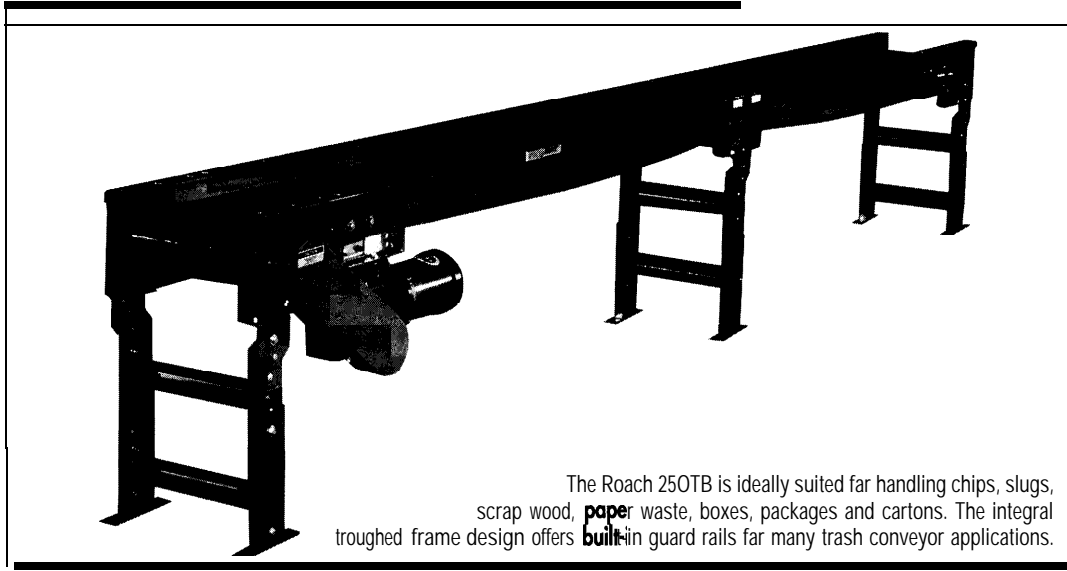

The Roach 250TB is ideally suited for handling chips, slugs, scrap wood, paper waste, boxes, packages and cartons. The integral troughed frame design offers built-in guard rails for many trash conveyor applications.

## SPECIFICATIONS

**BELTING:** PVC-I 20 block friction surface.

**DRIVE PULLEY:** 4" dia. with 1-3/16" dia. shaft or 8" dia. with 1-7/16" dia. shaft, both crowned and fully lagged.

**TAIL PULLEY:** 4" dia., crowned, with 1-3/16" dia. shaft.

**END DRIVE:** Allows one-direction (unit) operation; add optional center drive for reversible application.

**TAKE-UP:** Screw type unit at tail pulley provides 12" belt take-up.

**BEARINGS:** All pulley bearings are precision, heavy duty, lubricated, ball bearing units with cast iron housings.

**RETURN ROLLERS:** 1.9" dia., adjustable.

**BELT SPEED:** 60 FPM, constant.

**BED:** 2-1/2" deep x 12 ga. one piece formed construction with formed flanges on sides to provide extra strength.

**FLOOR SUPPORTS:** Adjustable 31"-40"

**TOB:** Supports provided at both ends and each bed joint. Supports can be lagged to floor.

**MOTOR DRIVE:** 1/3 HP 230/460/3, 60 cycle ODP right angle gear motor.

**ROLLER CHAIN:** Drive pulley is driven by No. 50 roller chain for 1-1/2 HP or less and No. 60 chain on larger drives. Chain take-up provided on motor base.

**ELECTRICAL CONTROLS:** Available as an option.

**CAUTION:** To prevent pinch points that exist when belt conveyors are permanently attached to other conveyors, use the connector brackets with safety pop out roller shown on page 147 (other stationary equipment will require proper guarding and safety devices supplied by others).

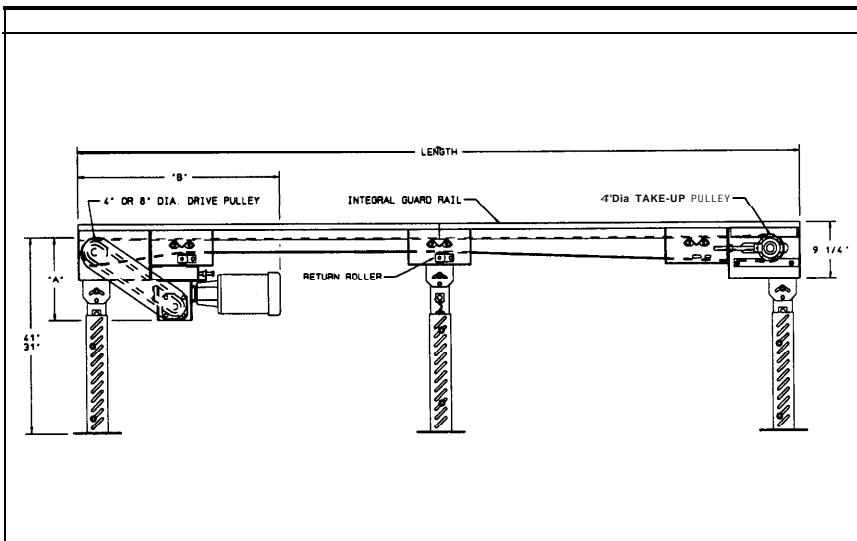

HP @ 60 FPM	REDUCER	"A"	"B"
1/3	RDW 13 120-02	12-3/4"	35-23/32"
1/2	RDW13120-02	12-3/4"	35-23/32"
3/4	RDW13340-02	13-3/8"	36-13/16"
1	RDW13150-01	15"	37-1/8"
1-1/2	RDW13150-02	15"	37-1/8"
2	RDW13200-02	16-3/8"	38-13/16"

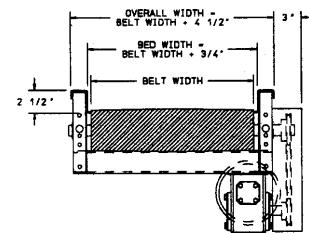

## SPECIFICATION TABLE

Up to 50'-0" will have a 4" dia. drive pulley, 51'-0" and over will have an 8" dia. drive pulley

CONVEYOR LENGTH			5'	10'	15'	20'	25'	30'	35'	40'	50'	60'	70'	80'	90'	100'						
BELT	BE	D	Unit weights (lbs.)																			
6"	7"	"	251	282	335	365	417	44	7	499	530	616	699	783	866	94	8	1031				
12"	13"	"	274	316	382	424	49	0	532	598	64	0	755	863	973	108	1	118	9	1297		
18"	19"	"	321	388	481	548	64	1	708	801	868	1038	119	8	137	0	152	0	167	9	1839	
24"	25"	"	374	43	0	536	615	721	800	90	0	085	118	3	1359	155	7	174	2	192	8	2113
30"	31"	"	39	9	457	572	659	77	4	861	976	1063	1281	1463	168	8	189	0	209	4	2296	
36"	37"	"	436	50	1	631	733	863	965	109	5	119	6	1447	1654	191	4	214	6	238	1	2612

## OPTIONAL EQUIPMENT

**BELTING** Black rubber ruff-top; neoprene smooth top with 3/64" cover (black or white - specify); 3-ply friction surface (FS x FS).

**BED DEPTH** For applications requiring a deeper trough, 400TB, 600TB and 800TB are available with integral bed trough depths of 4", 6" and 8". Consult factory.

**CENTER DRIVE** Reversible drive with integral belt take-up of 24". Specify location.

**SIDE MOUNTED END DRIVE** Provides minimum overall conveyor height of 9-1/2". Located on either side.

**AUXILIARY TAKE-UP** Provides 24" of belt take-up. Specify location.

**UNDERTRUSSED BED** Available to provide clearance underneath unit at bed joint locations. Specify location for undertrussing and desired clearance underneath unit.

**MOTORS** Available through 2 HP with characteristics such as totally enclosed, single phase, etc.

**BELT SPEED** Constant speed; **35-70 FPM** for 4" drive pulley and 45-90 FPM for 8" drive pulley (specify). Other constant or variable speeds available. **NOTE: CAPACITY CHANGES WITH SPEED.**

**FLOOR SUPPORTS** Other height supports available (adjustable or fixed]; also casted supports.

**CEILING HANGERS: 5/8" dia.** threaded rod with hardware to attach rods to conveyor. Provides 6' clearance between ceiling and TOB (furnished in place of floor supports).

**ELECTRICAL CONTROLS** Manual : start/stop push button switch; reversing drum switch; magnetic starter (one direction or reversible); limit switch; photo relay; others available.

LOAD CAPACITY @ 60 FPM			
HP	TOTAL CAPACITY	HP	TOTAL CAPACITY
1/3	300	1	725
1/2	400	1-1/2	1100
3/4	575	2	1300

## SIDE MOUNTED DRIVE

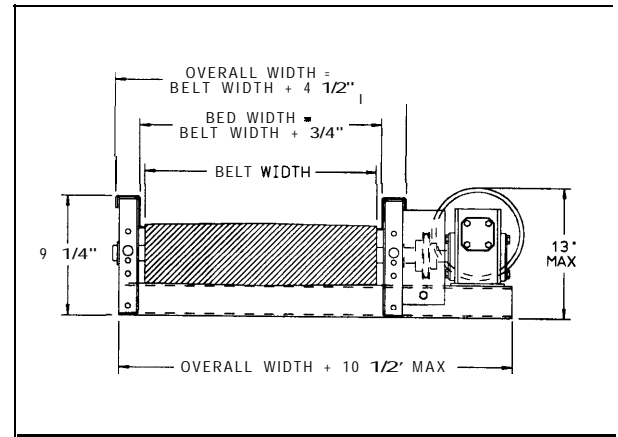

## OVERHEAD MOUNTED DRIVE

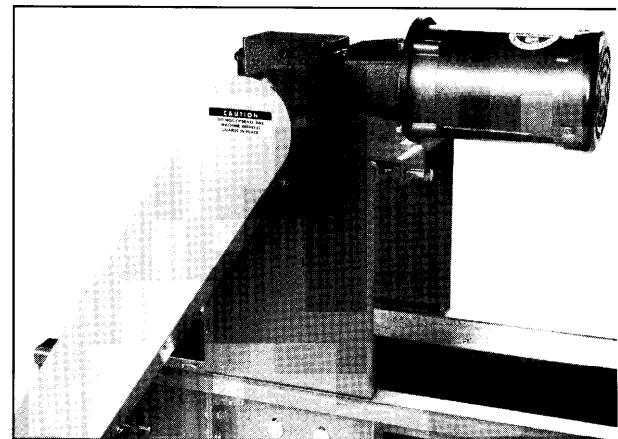

This gravity roller upender raises product to 45" interval for assembly operations. Contact the Roach national sales office at 501-483-7631 for additional information on any upenders--featuring gravity or powered conveyors or to upend various intervals to 90".