

# MODEL 297S 2-9/16" DIA. X 7 GA. STEEL GRAVITY ROLLER CONVEYOR

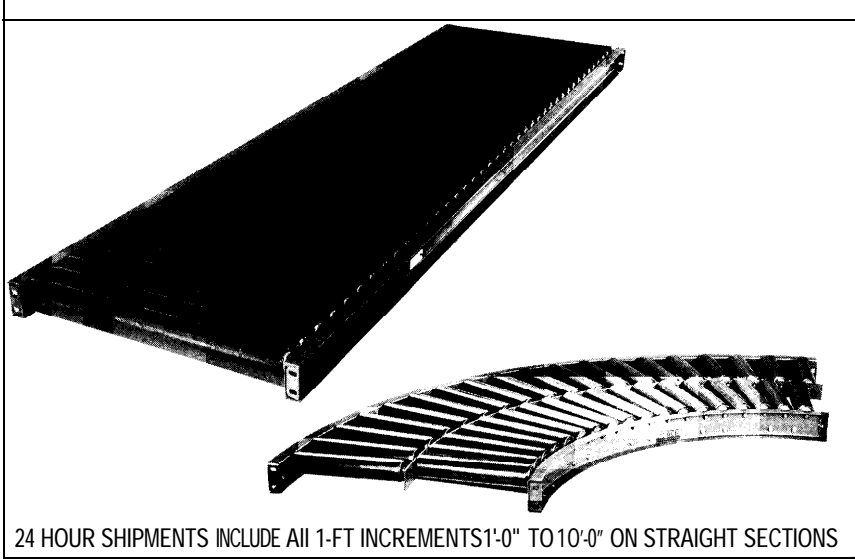

24 HOUR SHIPMENTS INCLUDE ALL 1-FT INCREMENTS 1'-0" TO 10'-0" ON STRAIGHT SECTIONS

## MODEL NO. EXPLANATION

297S\* -- 13 -- 3\*\* -- H -- 2  
 |  
 roller no. | | high/low |  
 BF RC length/degree

\*Specify "297SC" for curved sections.  
 \*\*Centers not required for curves

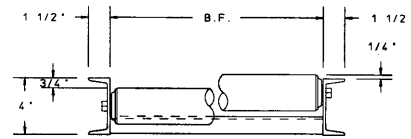

## SPECIFICATIONS

**ROLLERS:** 2-9/16" x 7 ga. steel tubing with straight ends, reamed to provide smooth bearing seats.

**FRAMES:** 4" at 5.4 lbs. structural steel channel.

**BEARINGS:** Removable type, heavy duty ball bearings, zinc plated, grease packed.

**COUPLINGS:** Butt type.

**AXLES:** 11/16" hex shaft, spring loaded.

**CAPACITY:** 540 lbs. per roller, or 3750 lbs. maximum distributed live load per 10' section with supports at 10' centers; 8000 lbs. at 5' centers.

## STRAIGHT SECTIONS

NOM RLR. BF	UNIT WEIGHTS (lbs.)									
	3" RC		4 1/2" RC		6" RC		9" RC		12" RC	
	10'	5'	10'	5'	10'	5'	10'	5'	10'	5'
12" 13"	425	216	349	178	272	140	228	118	196	101
14" 15"	467	238	381	194	294	151	244	126	207	108
16" 17"	509	259	413	211	316	162	259	134	219	114
18" 19"	551	281	444	227	338	174	275	142	231	120
20" 21"	593	302	476	244	360	185	291	151	243	127
22" 23"	635	323	508	260	381	197	308	160	254	133
24" 25"	677	345	540	276	403	208	323	168	266	139
26" 27"	719	366	572	293	425	219	338	175	278	146
30" 31"	803	409	636	325	469	242	370	193	302	158
32" 33"	845	430	668	342	490	253	385	201	313	165
36" 37"	929	473	731	375	534	276	418	218	337	177
38" 39"	971	495	763	391	556	287	432	225	349	184
42" 43"	1055	538	827	424	600	310	463	242	373	197
46" 47"	1139	581	890	457	643	332	495	258	396	210
50" 51"	1223	624	954	489	687	355	526	274	420	222

**CAUTION:** To prevent pinch points that exist when gravity conveyors are permanently attached to power conveyors, use the connector brackets with safety pop-out rollers shown on page 147.

## UNIT CURVED SECTIONS

NOMER	ING	BF	INSIDE RADIUS	90°			45° *degrees		
				ROLLERS PER CURVE	ROLLER PATTERN	WEIGHT (lbs.)	ROLLERS PER CURVE	ROLLER PATTERN	WEIGHT (lbs.)
12"	13"	2'-8 1/2"	18	SINGLE	190	9	SINGLE	96	
14"	15"	2'-8 1/2"	18	SINGLE	209	9	SINGLE	106	
16"	17"	2'-8 1/2"	18	SINGLE	229	9	SINGLE	116	
18"	19"	2'-8 1/2"	18	SINGLE	248	9	SINGLE	125	
20"	21"	2'-8 1/2"	18	SINGLE	267	9	SINGLE	134	
22"	23"	2'-8 1/2"	18	SINGLE	286	9	SINGLE	144	
24"	25"	2'-8 1/2"	18	SINGLE	306	9	SINGLE	154	
26"	27"	2'-8 1/2"	18	SINGLE	325	9	SINGLE	164	
30"	31"	4'-0"	40	DOUBLE	443	20	DOUBLE	242	
32"	33"	4'-0"	40	DOUBLE	484	20	DOUBLE	263	
36"	37"	4'-0"	40	DOUBLE	528	20	DOUBLE	287	
38"	39"	4'-0"	40	DOUBLE	550	20	DOUBLE	299	
42"	43"	4'-0"	40	DOUBLE	604	20	DOUBLE	328	
46"	47"	4'-0"	40	DOUBLE	657	20	DOUBLE	356	
50"	51"	4'-0"	40	DOUBLE	711	20	DOUBLE	385	

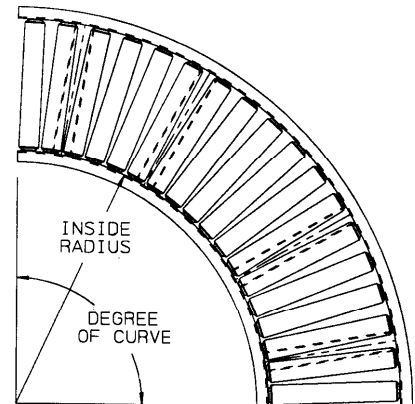

24 hour shipment



MODEL 254TC  
2-1/2" DIA. X 14 GA. TAPERED ROLLER CURVE

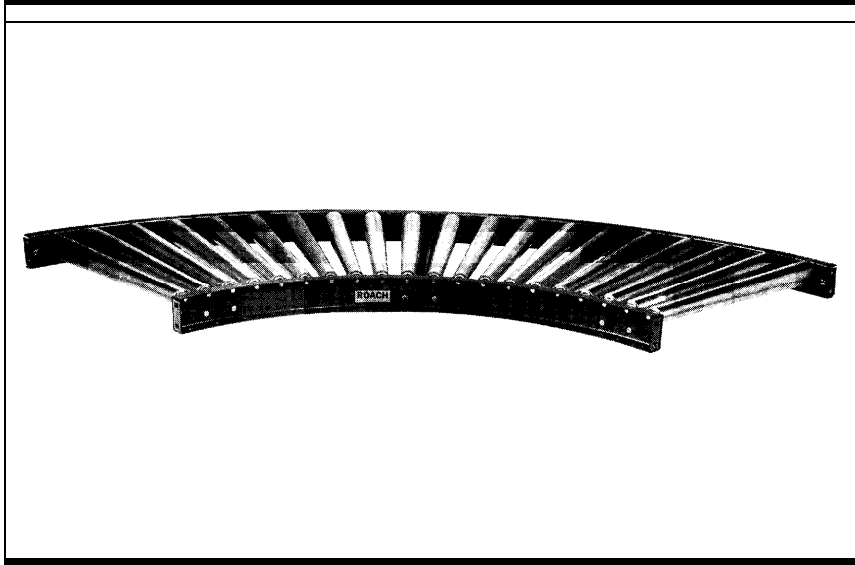

MODEL NO. EXPLANATION

254TC -- 13 -- H -- 90  
 roller no. high/low degree  
 BF

SPECIFICATIONS

TAPERED ROLLERS: 2-1/2" to 1 - 1 1/16" dia. x 14 ga. steel tubing with smooth swaged ends.

FRAMES: Formed steel channel 3-1/2" x 1-1/2" x 10 ga.

BEARINGS: Integral Labyrinth sealed ball bearings, zinc plated, grease packed, removable type.

COUPLINGS: Butt type.

AXLES: 6" hex shaft, spring loaded.

CAPACITY: 250 lbs. per roller, or 650 lbs. maximum distributed live load with supports at each end of curve section and at the outside of a 90° curve section.

Indoff Distributor 860-632-2026

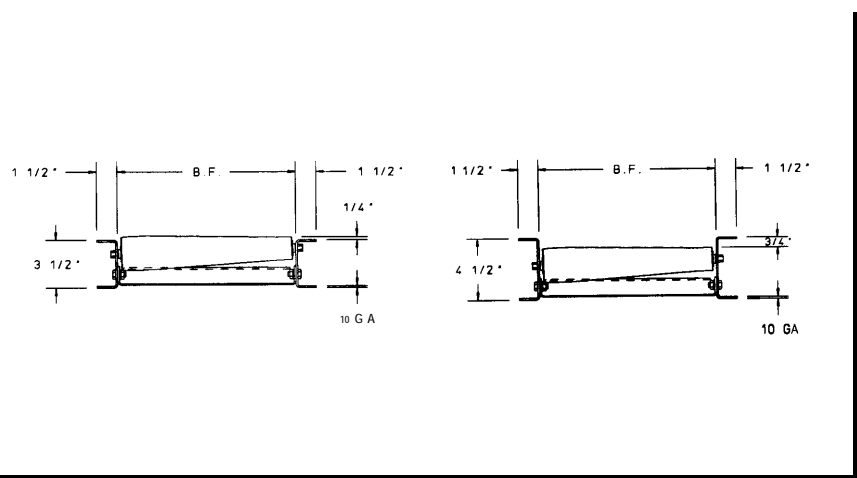

CAUTION: To prevent pinch points that exist when gravity conveyors are permanently attached to power conveyors, use the connector brackets with safety pop-out rollers shown on page 147.

UNIT			90°		45°	
NOM. LENGTH	RLR. BF	INSIDE RADIUS	ROLLERS PER CURVE	WEIGHT (lbs.)	ROLLERS PER CURVE	WEIGHT (lbs.)
12"	13"	2'-8 1/2"	20	104	10	57
14"	15"	2'-8 1/2"	20	137	10	74
16"	17"	2'-8 1/2"	20	150	10	81
18"	19"	2'-8 1/2"	20	168	10	89
20"	21"	2'-8 1/2"	20	185	10	98
22"	23"	2'-8 1/2"	20	195	10	104
24"	25"	2'-8 1/2"	20	215	10	118
26"	27"	2'-8 1/2"	20	228	10	120
30"	31"	4'-0"	32	377	16	195
32"	33"	4'-0"	32	390	16	202
36"	37"	4'-0"	32	418	16	216
38"	39"	4'-0"	32	459	16	236
42"	43"	4'-0"	32	500	16	257
46"	47"	4'-0"	32	541	16	277
50"	51"	4'-0"	32	582	16	298

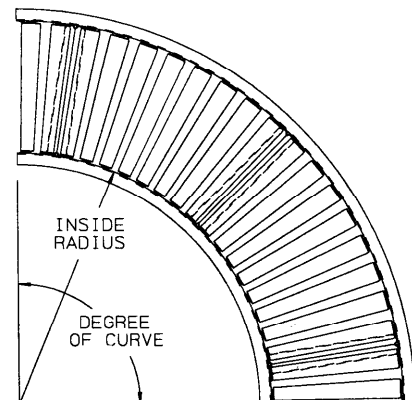

■ 24 hour shipment