

Model 81P – Roll Lifting “C” Hooks

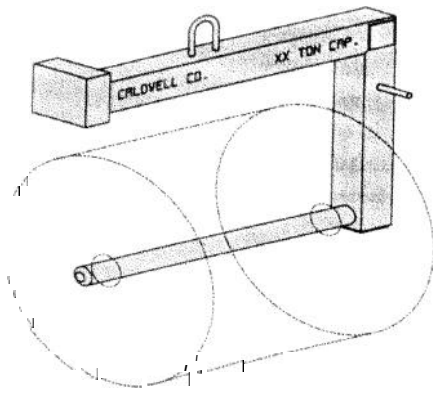

This Caldwell Model 81 Roll Lifter is designed to handle rolls by inserting a round arm into the roll I.D. This unit is counter-balanced to hang level when empty for ease of insertion into the roll core. Guide handle is standard. Lifter parking stand can be furnished if required.

Capacities: To 5 Ton.

Indoff

www.mh-partners.com
sales@mh-partners.com

Model 90P or 90 – Pallet or O.D. Lifters

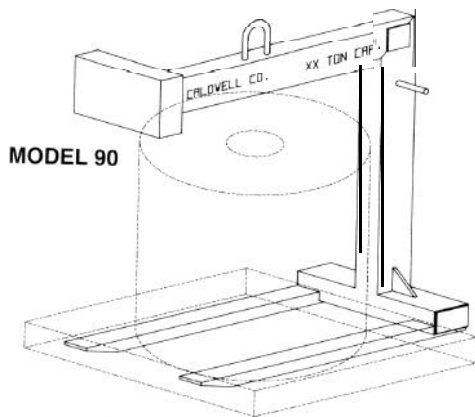

MODEL 90 PALLET LIFTERS

The Caldwell Model 90 Pallet Lifter allows your overhead crane to be converted into an overhead lift truck. Models are available with pry bar and/or hand wheel adjustment for fork widths.

Capacities: To 10 Ton.

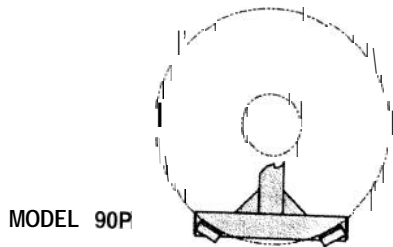

MODEL 90P ROLL LIFTERS

The Caldwell Model 90P Pallet Type Roll Lifter has been designed to lift and transport a roll by supporting it underneath its diameter, leaving the core open if required.

Capacities: To 10 Ton.

Model 88 – Roll Positioners

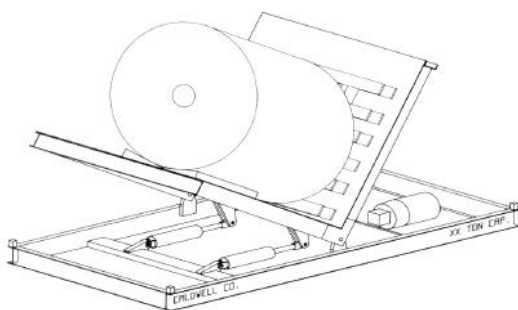

This Caldwell Model 88L Low Platform Roll Upender/Downender allows rolls to be repositioned by rotation. The low platform is desirable in those applications where headroom is restricted. Hydraulic controls are standard.

Capacities: To 7% Ton.

The Heavy Duty Model 88 Roll Positioner is available with a mechanical drive. This model requires additional platform height.

Capacities: To 30 Ton.