

Model 85P – Motorized Roll Lifters

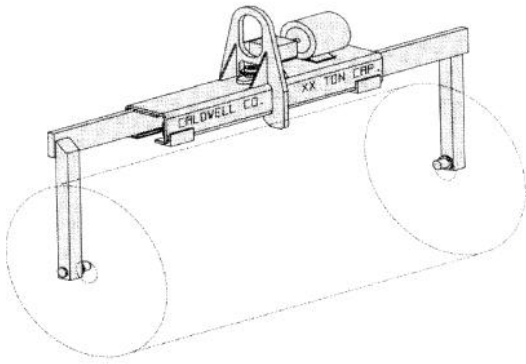

Used to lift rolls by positioning lifting pins in the I.D. of the roll. Arms actuate in and out to clear and lift roll. This model will handle a variety of widths with minimal aisle clearance requirements. Motorization is recommended; however, chainwheel operation is available.

Capacities: To 10 Ton.

Model 75P – Roll Grabs

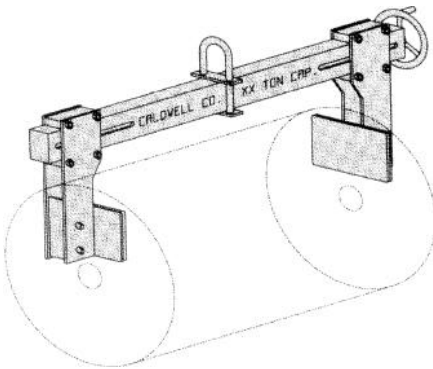

Used for side lifting of rolls by gripping on the ends. A wide range of roll lengths or widths can be accommodated. Motorization is recommended when handling a wide range of roll widths.

Capacities: To 5 Ton.

Indoff

www.mh-partners.com
sales@mh-partners.com

Model 74P – Roll Gripping Tong^{gs}

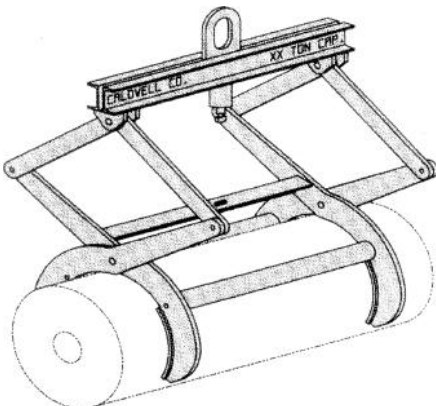

Used to grip the O.D. of a roll. The diameter range can vary up to 25%. A double leg design will provide additional roll stability, however single leg models are available for narrower rolls. Recommend double leg for rolls wider than 48".

Features: Automatic latching mechanism for single-person operation. Tong saddles with protective covering to prevent roll damage are available.

Capacities: Double Leg to 4 Ton.
Single Leg to 2 1/2 Ton.